

---

# JET PUMP REPAIR PARTS



### INDEX

#### JETS

JRS.....	3
JRD.....	4
JRSG.....	moved to obsolete book
J+ and JS+.....	5
JB.....	moved to obsolete book
HSJ.....	6
VJ.....	7
SJ.....	8
GT Irri-Gator™.....	9
BF03S.....	10

The 10K2 has been replaced in production and as a repair part by the 10K10. The 10K10, John Crane Type 6, is a superior seal with a carbon rotary face, a ceramic stationary seat and BUNA N elastomers.

### MODEL JRS

Item No.	Part Description	Material	Repair Part No.				
			JRS5	JRS5H	JRS5LT	JRS7	JRS10
1	Drain plug 1/4" NPT	Steel	6K2				
2	Vent plug 1/8" NPT	Steel	6K1				
3	Elbow connector – tubing	Polypropylene	6K94				
4	Casing	Cast iron	1K342		1K382	1K342	
5	Nozzle	Delrin®	AN018	AN020	AN018		
6	Venturi tube	Lexan®	AD3330	AD3325	AD3330	AD3336	AD3339
7	Separator plate seal ring	BUNA-N	5K323				
8	Separator plate	Polypropylene	5K253				
9	Diffuser (guidevane)	Lexan®	3K64			3K65	
10	Impeller	Noryl®	2K900			2K901	2K902
11	O-ring	BUNA	5K230				
12	Mechanical seal – Rotary	Teepelite	10K10				
13	Mechanical seal – Stationary	Ceramic	10K10				
14	Seal housing	Amodel®	1K366				
15	Connector with locknut	Steel	6K24				
16	Pressure switch	NA	AS4				
17	Tubing – pressure switch	Polypropylene	6K92			6K101	6K108
18	Motor	Stainless steel shaft	SFJ04860			SFJ05860	SFJ06860
19	Hex cap screw	Steel	13K80				
20	Grommet – base	BUNA	4K405				
21	Base – JRS5, JRS7, JRS10 (off tank)	Steel	4K399		4K449	4K399	
	Tank base – JRS5LT (on tank model)						
22	Discharge gland washers (pkg 2)	N-8090	–		5K10	–	
23	Discharge gland packing	BUNA	–		5K8	–	
24	Dis. gland nut assembly (includes 22 & 23)	Brass	–		4K12	–	

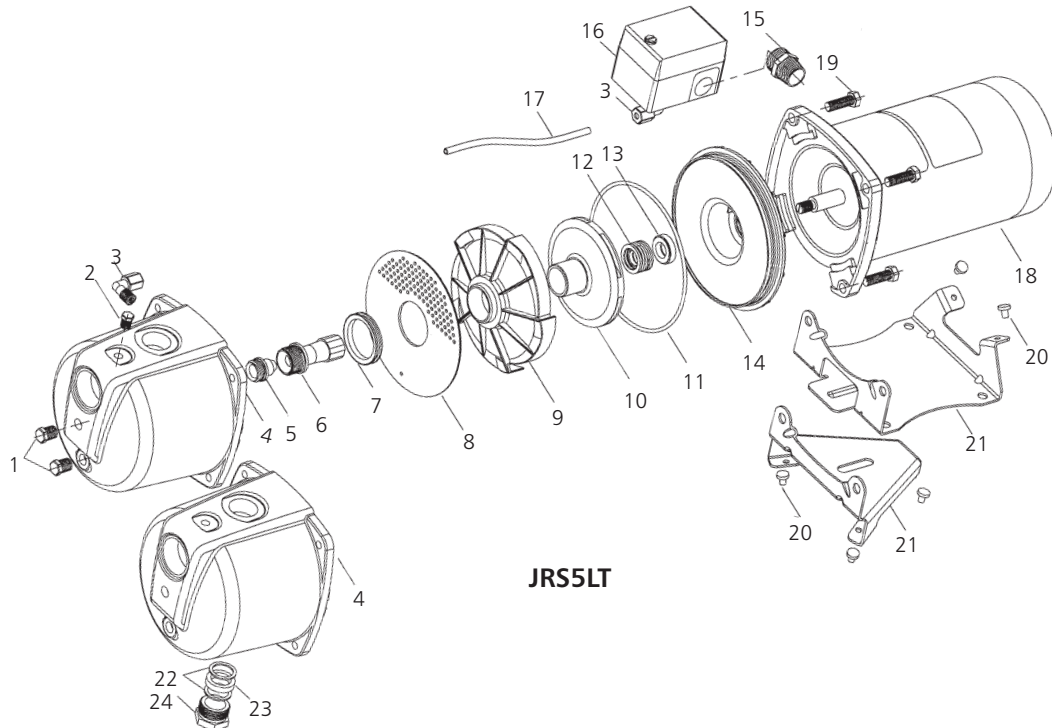

### MODEL JRD

Item No.	Part Description	Material	Repair Part No.			
			JRD5	JRD5LT	JRD7	JRD10
1	Pipe plug 1/2" NPT	Steel		6K68		
2	Hex cap screw	Steel		13K1		
3	Shallow well adapter	Cast iron		4K62		
4	Pipe plug 1/8" NPT	Steel		6K1		
5	Gasket	BUNA – FDA/NSF		5K108		
6	Nozzle	Delrin®		AN018		
7	Venturi tube	Lexan®	AD3731		AD3536	AD3538
8	Drain plug 1/4" NPT	Steel		6K2		
9	Elbow connector – tubing	Polypropylene		6K94		
10	Casing	Cast iron	1K416	1K417	1K416	
11	Separator plate seal ring	BUNA		5K323		
12	Separator plate	Polypropylene		5K253		
13	Diffuser (guide vane)	Lexan®	3K64		3K65	
14	Impeller	Noryl®	2K900		2K901	2K902
15	O-ring	BUNA		5K230		
16	Mechanical seal – rotary	Teepelite		10K10		
17	Mechanical seal – stationary	Ceramic		1K366		
18	Seal housing	Amodel®		6K24		
19	Connector w/locknut	Steel		AS4		
20	Pressure switch	NA		6K92		
21	Tubing – pressure switch	Polypropylene		6K101		6K108
22	Motor	Stainless steel shaft	SFJ04860	SFJ05860		SFJ06860
23	Hex cap screw	Steel		13K80		
24	Grommet – base	BUNA		4K405		
25	Base – JRD5, JRD7, JRD10 (off tank)	Steel	4K399	4K449	4K399	
	Tank base – JRD5LT (on tank)					
26	Discharge gland washers (pkg 2)	N-8090	–	5K10	–	
27	Discharge gland packing	BUNA	–	5K8	–	
28	Dis. gland nut assembly (includes 26 & 27)	Brass	–	4K12	–	

### JRD with Shallow Well Adapter

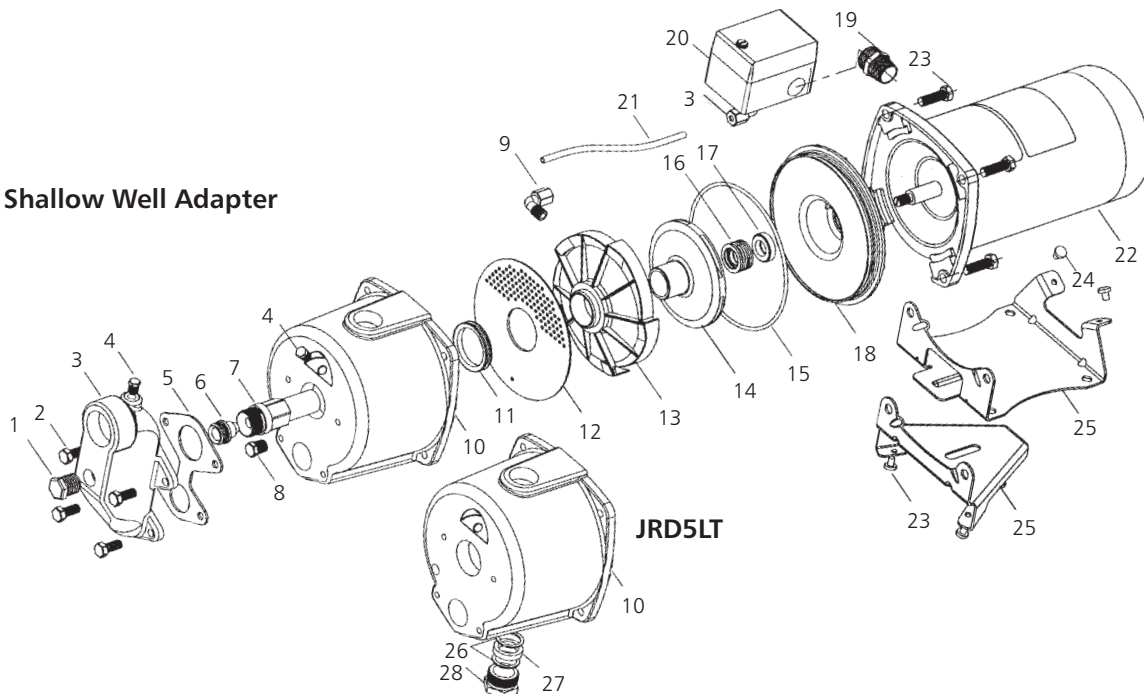

## Residential Water Systems

### MODEL J+ and JS+

Item No.	Part Description	Material	J+ Series Repair Part No.					JS+ Series Repair Part No.				
			J5	J5H	J7	J10	J15	J5S	J5SH	J7S	J10S	J15S
1	Pipe plug – 1/2" NPT	Steel, plated	6K68					-				
2	Hex cap screw	Steel	13K1					-				
3	Pipe plug – 1/8" NPT	Steel, plated	6K1					6K1				
4	Shallow well adapter	Cast iron	4K62					-				
5	Nozzle	Delrin®	AN017	AN019	ANO18		AN022	AN017	AN019	ANO18		AN022
6	Venturi tube	Lexan® on model JS+	AD3731	AD3528	AD3536	AD3538	AD3542	AD3332	AD3328	AD3336	AD3339	AD3342
		Durez® on model J+										
7	Gasket	BUNA - FDA/NSF	5K108					-				
8	Drain plug – 1/4" NPT	Steel, plated	6K2					6K2				
9	Straight connector	Polypropylene	6K100					6K100				
10	Casing	Cast iron	1K311 (59395)					1K333 (59240)				
11	Seal ring	BUNA - FDA/NSF	5K6 or 5K231 ①					5K6 or 5K231 ①				
12	Diaphragm	BUNA - FDA/NSF	5K162					5K162				
13	Tubing	Polypropylene	6K92	6K93	6K101	6K102	6K92	6K93	6K101	6K102		
14	Diffuser (guidevane)	Lexan® 10% G.F.	3K75	3K67		3K68	3K75	3K67		3K68		
15	Impeller	Noryl® 20% G.F.	2K4	2K60	2K61	2K706	2K4	2K60	2K61	2K706		
16	Mechanical seal, rotary	Teepelite	10K10					10K10				
17	Mechanical seal, stationary	Ceramic	10K10					10K10				
18	Motor adapter	Cast iron	1K310 (59394)					1K310 (59394)				
19	Casing bolts	Steel	13K102					13K102				
20	Elbow connector	Polypropylene	6K94					6K94				
21	Motor adapter bolts	Steel	13K69					13K69				
22	Motor	Stainless steel shaft	J04853R	J05853R	J06853R	J07858R	J04853R	J05853R	J06853R	J07858R		
23	Pressure switch	NA	AS4					AS4				
24	Pump foot	Steel	4K408					4K408				
24A	Pump Base Assembly with Rubber Channel <b>Replaces foot 4K408</b>	Steel	-			15K60	-			15K60		
25	Pump foot bolt	Steel	13K252					13K252				
26	Switch con. with locknut	Steel	6K24					6K24				
27	Fillister head machine screw	Stainless steel	13K4					13K4				
28	Deflector	BUNA	5K7					5K7				

#### NOT SHOWN:

Casing J05LT for tank mounted models 1K58  
 Gland Nut Assembly for J05LT 4K12  
 Bottom Plug for 1K58 6K59

① Use 5K6 with any bolt-in diffuser.  
 Use 5K264 with snap-in diffuser (no bolts).

15K60 effective 9-05.

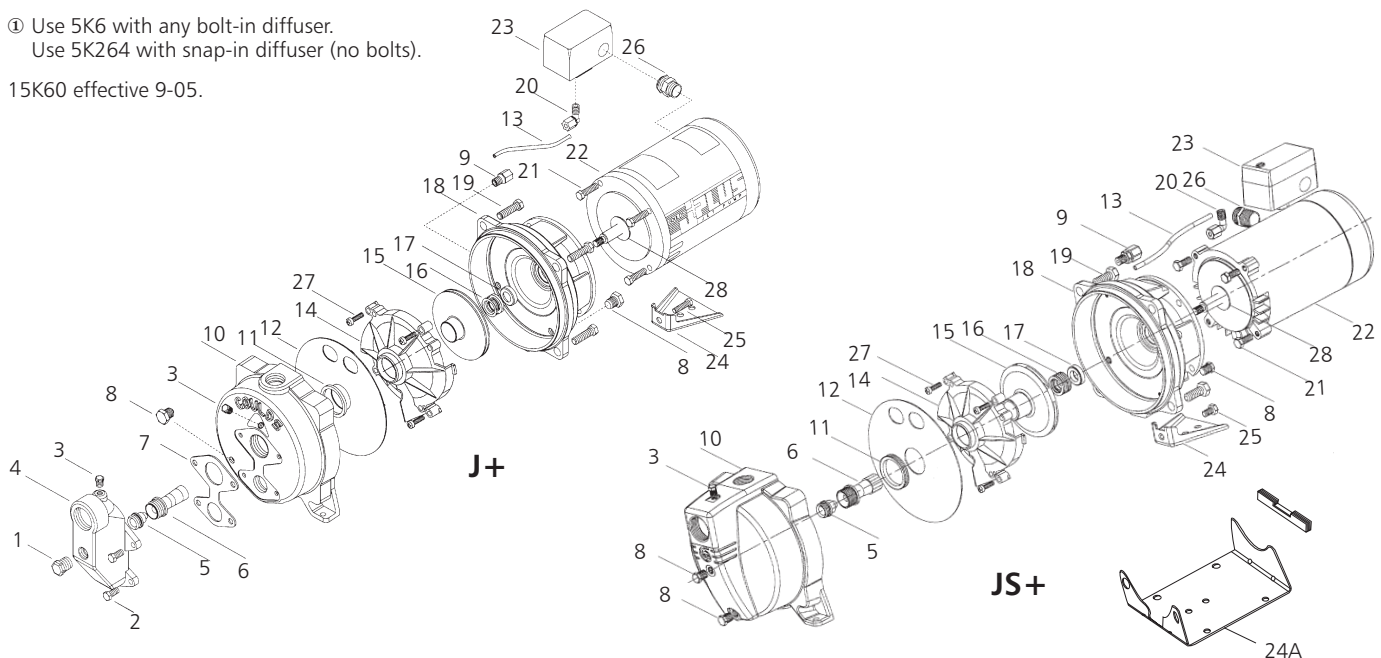

### MODEL HSJ

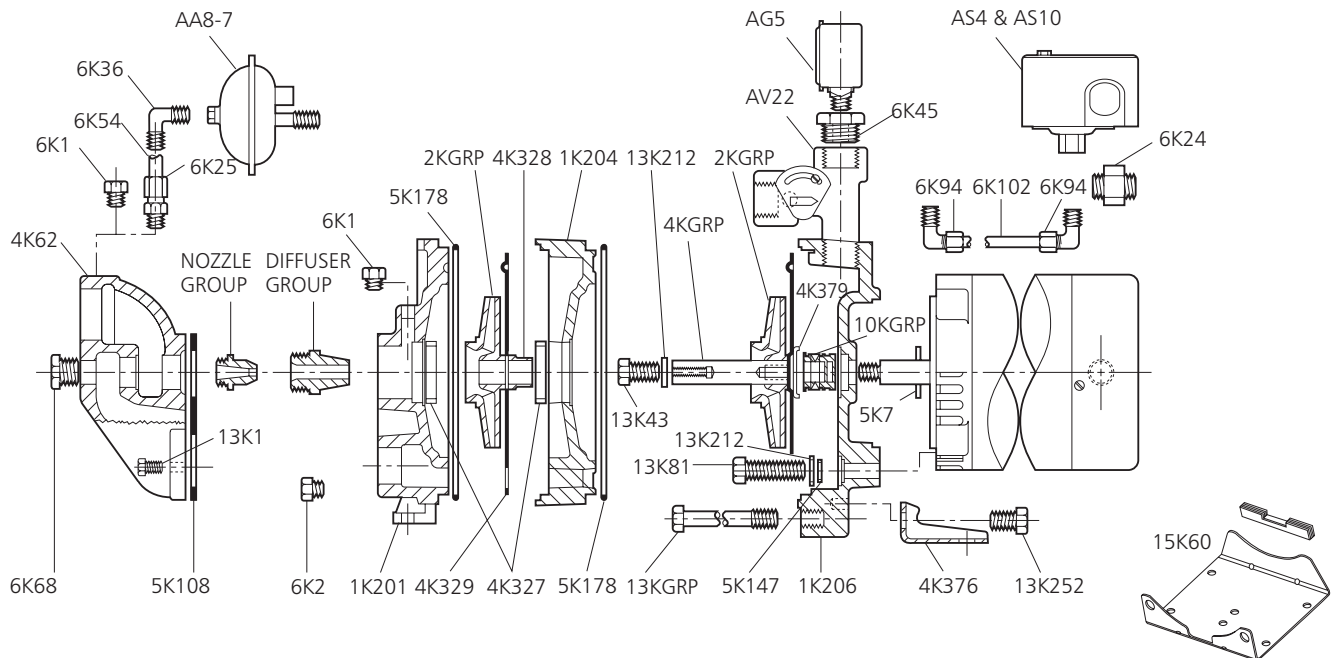

Part No.	Part Name	Pattern No.
① 1K201 1K204 1K206	Casing (4 bolt S.W.A.) Intermediate stage Motor adapter	59160 59157 59156
2K289 2K290	Impeller – ¾ and 1½ HP HSJ models Impeller – 1 and 2 HP HSJ models	
4K62 4K308 4K327 4K328 4K329	Adapter – shallow well (4 bolt) Foot - old style (cast) Wear ring Sleeve Coverplate – 1 per stage	55548
② 4K331 ② 4K332 4K376 15K60 4K379	Shaft extension – 2 stage, ¾ and 1 HP Shaft extension – 3 stage, 1½ and 2 HP Foot - (stamped) Pump Base Assembly with Rubber Channel <b>Replaces foot 4K408</b> Retainer – shaft sleeve assembly	
5K7 5K147 5K108 5K178	Deflector O-ring – motor adapter bolts Gasket – S.W. adapter (4 bolt) O-ring – casing and intermediate stage	
6K1 6K2 6K24 6K25 6K36 6K45 6K68 6K94 6K102	Pipe plug ⅛" NPT Pipe plug ¼" NPT Switch connector with nut Comp. fitting ⅛" NPT x ¼" tubing Comp. fitting elbow ⅛" NPT x ¼" tubing Reducing bushing ¼" x 1" NPT Pipe plug ½" NPT Elbow fitting (tubing) Tubing	
10K10	Shaft seal assembly	
13K43 13K71 13K81 13K1 13K212 13K213 13K214 13K252	Impeller bolt Bolt – foot to adapter (old foot) Bolt – adapter to motor Bolt – S.W. adapter (4 bolt) Washer – impeller and adapter Bolt – casing to adapter, 2 stage models Bolt – casing to adapter, 3 stage models Bolt – foot to adapter	

Part No.	Part Name	Pattern No.
AG2	Pressure gauge – 200 PSI maximum	
AG5	Pressure gauge – 100 PSI maximum	
AS4	Pressure switch – ¾, 1, 1½ HP rated	
AS10	Pressure switch – 2 HP rated	
AV22	Pressure control valve	
AA8-7	Air volume control valve – used with galvanized tanks	

### MOTOR CODES

HP	Model	Order No.
¾	HSJ07N, 2 stage	J05853R
1	HSJ10N, 2 stage	J06853R
1½	HSJ15N, 3 stage	J07858R
2	HSJ20N, 3 stage	J08854R

### SHALLOW WELL FITTINGS PACKAGES

HP	Model	Nozzle Group	Diffuser Group
¾	HSJ07N	AN012	AD3432
1	HSJ10N	AN012	AD3437
1½	HSJ15N	AN012	AD3439
2	HSJ20N	AN012	AD3448

### 2 BOLT SHALLOW WELL ADAPTER – OBSOLETE (NOT AVAILABLE)

4K312	Adapter – shallow well (2 bolt)
5K173	Gasket – shallow well adapter (2 bolt)
13K1	Bolt – shallow well adapter (2 bolt)

① Casing for 2 bolt shallow well adapter not available. Order 1K261 kit which includes pump casing, 4 bolt adapter, gasket and bolts.

② Includes 4K379, 13K43 and 13K212.

### MODEL VJ

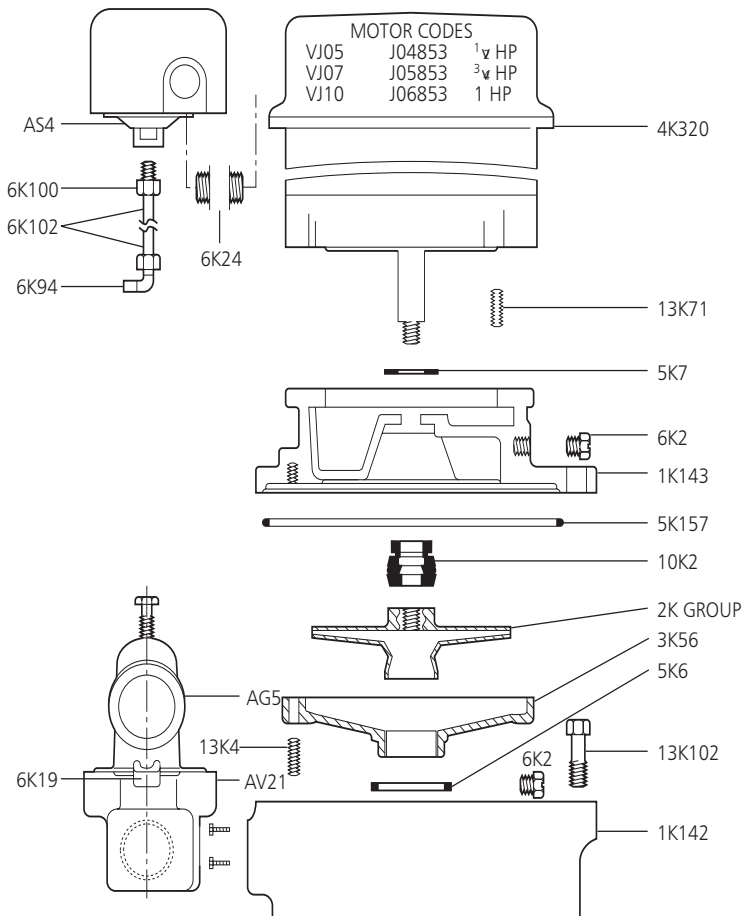

Part No.	Part Name	Pattern No.
1K142	Casing	59202
1K143	Motor adapter	59014
2K61	Impeller 3/4 and 1 HP	2K GROUP
2K204	Impeller 1/2 HP	
3K56	Guidevane - 1/2, 3/4, 1 HP	
4K230	Drip cover - 48FR (A.O. Smith motor)	
5K6	Seal ring - guidevane	
5K7	Deflector	
5K157	O-ring	
6K2	Plug 1/4 NPT	
6K19	Reducing bushing 3/4" x 1/4" (for AG5)	
6K24	Switch connector with nut	
6K94	Elbow fitting (tubing)	
6K100	Straight fitting (tubing)	
6K102	Tubing	
10K10	Shaft seal assembly	
13K4	Screw - guidevane	
13K71	Bolt - motor adapter to motor	
13K102	Bolt - casing to motor adapter	
AG5	Pressure gauge	54382
AS4	Pressure switch	
AV21	Pressure control valve	

### MODEL SJ

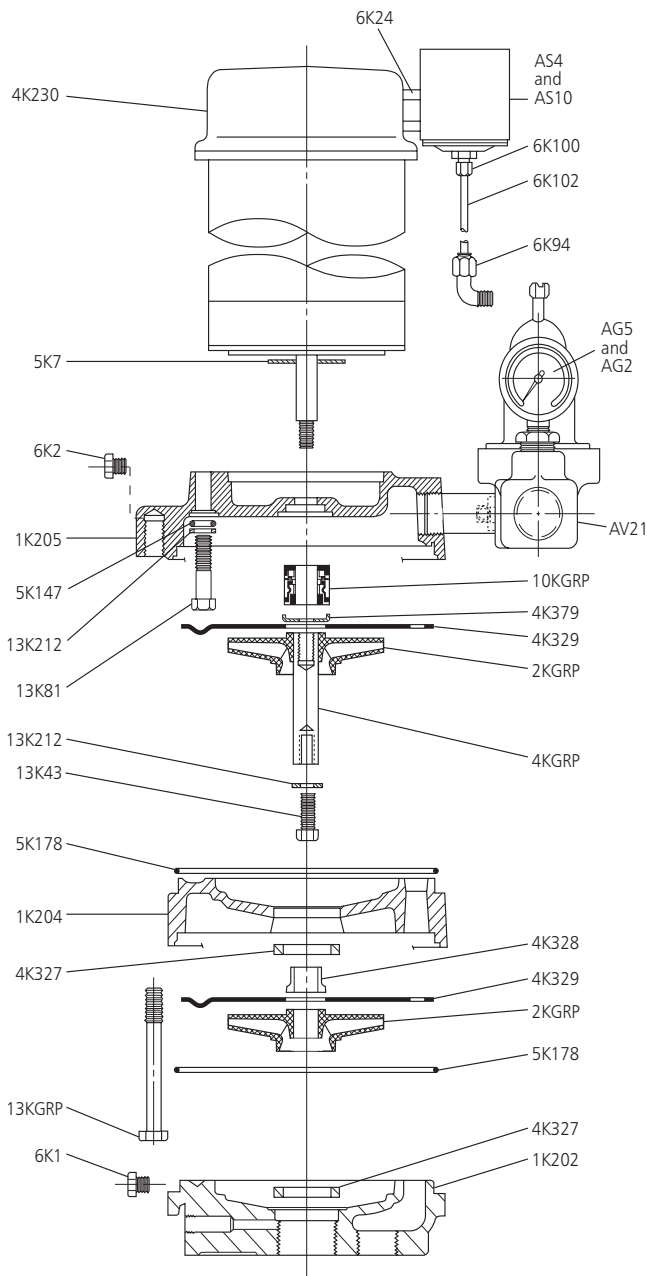

Part No.	Part Name	Pattern No.
1K202	Casing – twin pipe system and packer	59159
1K203	Casing – packer system (OBSOLETE)	Use 1K202
1K204	Intermediate stage	59157
1K205	Motor adapter	59156
2K289	Impeller – ¾ and 1½ HP models	
2K290	Impeller – 1 and 2 HP models	
4K230	Drip cover	
4K327	Wear ring	
4K328	Sleeve	
4K329	Coverplate	
4K379	Retainer – shaft seal assembly	
①4K331	Shaft extension – 2 stage, ¾ and 1 HP models	
①4K332	Shaft extension – 3 stage, 1½ and 2 HP models	
②4K375	Retaining ring (OBSOLETE)	
5K7	Deflector	
5K147	O-ring – motor adapter bolts	
5K178	O-ring – casing and intermediate stage	
6K1	Pipe plug ⅛" NPT	
6K2	Pipe plug ¼" NPT	
6K19	Reducing bushing ¼" x ¾" NPT	
6K24	Switch connector with nut	
6K94	Elbow fitting (tubing)	
6K100	Straight fitting (tubing)	
6K102	Tubing	
10K10	Shaft seal assembly	
13K43	Impeller bolt	
13K81	Bolt – adapter to motor	
13K212	Washer – impeller and adapter	
13K213	Bolt – casing to adapter ¾ and 1 HP models	
13K214	Bolt – casing to adapter 1½ and 2 HP models	
②13K250	Impeller washer (OBSOLETE)	
AG2	Pressure gauge – 200 PSI max.	
AG5	Pressure gauge – 100 PSI max.	
AS4	Pressure switch – ¾, 1 HP, 1½ HP rated	
AS10	Pressure switch – 2 HP rated	
AV21	Pressure control valve	
AA8-7	Air volume control valve (not shown)	

① Includes 4K379, 13K43 and 13K212.

② Models built December 1988 through February 1991 used a retaining ring. Replace with 4K331 or 4K332 shaft extension assembly.

### MOTOR CODES

HP	Model	Order No.
¾	SJ07, SJ07PK	JO5853R
1	SJ10, SJ10PK	JO6853R
1½	SJ15, SJ15PK	JO7858R
2	SJ20, SJ20PK	JO8854R



### MODEL GT IRRI-GATOR

Item No.	Description	Material	Part No.				
			GT07/ GT073	GT10/ GT103	GT15/ GT153	GT20/ GT203	GT30/ GT303
1	1/4" NPT Pipe Plug	Plated Steel	6K2				
2	Casing	Cast Iron	1K324				
3	Guidevane Seal Ring	BUNA	5K6				
4	Diaphragm	Neoprene	5K256				
5	Fillister Head Machine Screw	Stainless Steel	13K4	13K4	13K2	13K2	13K2
6	Guidevane	Lexan® 10% G.F.	3K72	3K71	3K70	3K70	3K69
7	Impeller	Noryl® 20% G.F.	2K715	2K716	2K714	2K713	2K712
8	Mechanical Seal	Carbon/Ceramic/BUNA	10K10				
9A	Pump Foot (old style)	Steel	4K408				
9B	Pump Base Assembly with Rubber Channel <b>Replaces foot 4K408</b>		15K60 (effective 9-05)				
9C	Tall Pump Base with Rubber Channel <b>Replaces 15K60 or 4K408</b>	Steel	15K86				
10	Pump Foot Bolt <b>use with 4K408 only</b>	Steel	13K252				
11	Motor Adapter	Cast Iron	1K310				
12	Casing Bolt	Steel	13K102 (4 required)				
13	Motor Adapter Bolt	Steel	13K69				
14	Deflector	BUNA	5K7				

HP	Motor Codes			
	1Ø – ODP	3Ø – ODP	1Ø – TEFC	3Ø – TEFC
.75	J05853R	C05873	C06821	C06876
1.0	J06853R	C06873	C07821	C07876
1.5	J07858R	C07878	C08821	C08876
2.0	J08854R	C08874	C09821	C09876
3.0	J09853	C09874	C09821	C09876

**NOTE:**

Many TEFC motors have a 1.0 Service Factor, while ODP motors have NEMA Service Factors between 1.15 and 1.6. Therefore, the motor HP will be higher for TEFC models than ODP models. Ex. A GT15 has a 1.5 HP, ODP motor with a 1.3 S.F., the GT153 will require a 2 HP TEFC motor which has a 1.0 S.F. The Price Book shows the actual HP motor used on each model while this chart shows only motor order numbers.

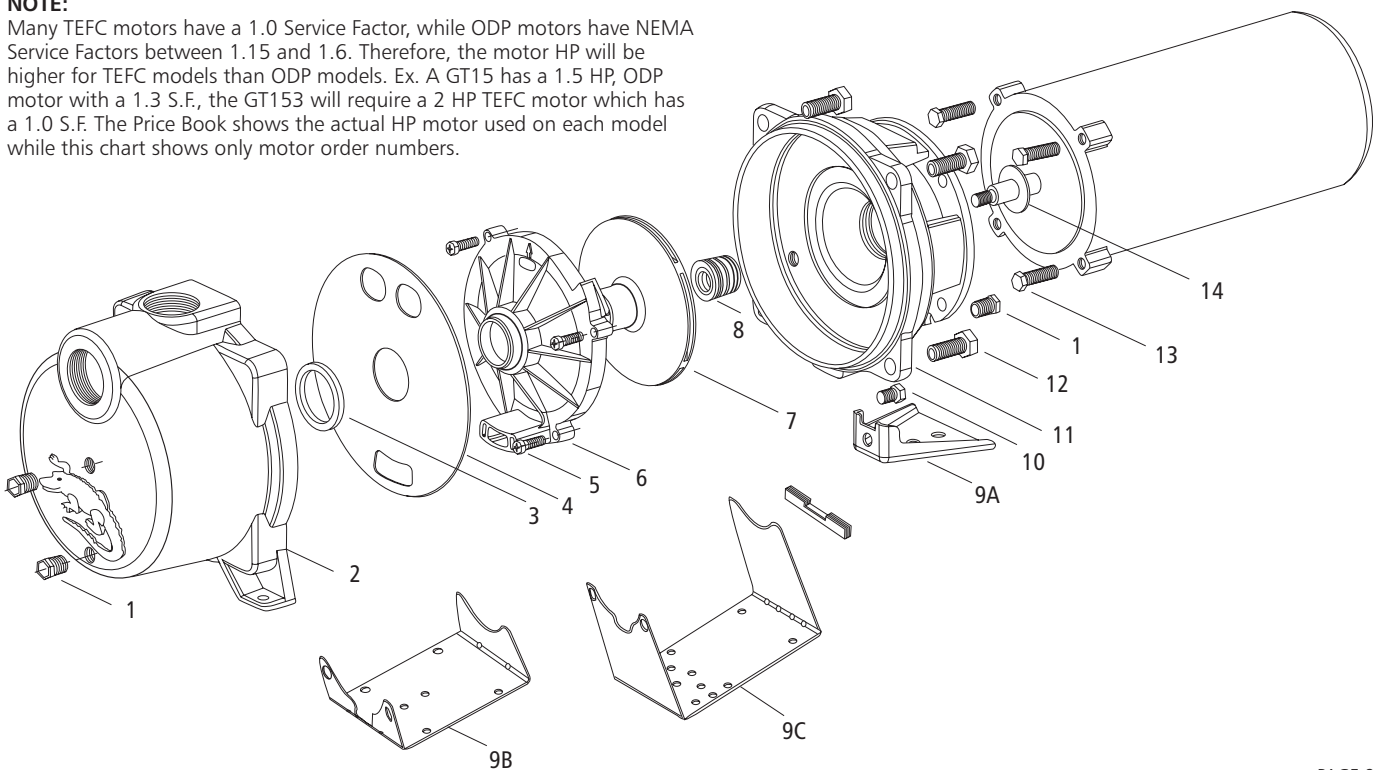

### MODEL BF03S

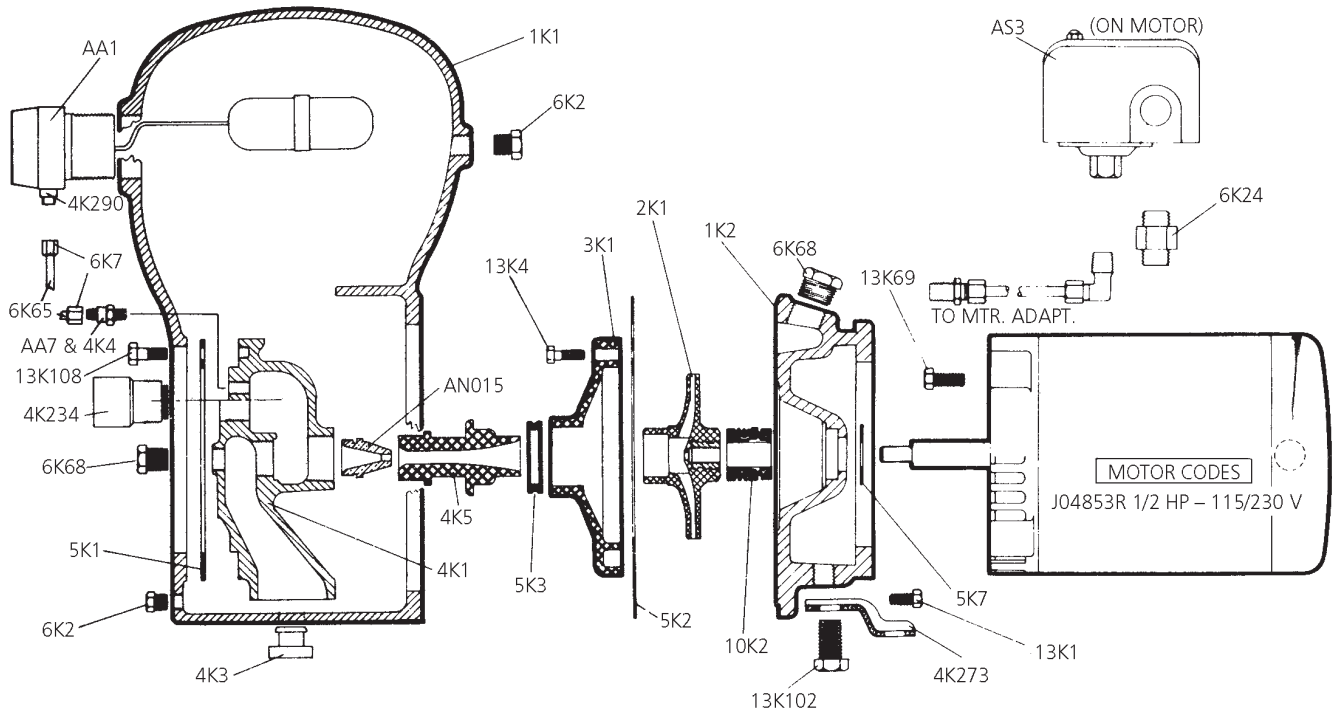

Part No.	Part Name	Pattern No.
1K1	Casing with plug and 2 grommets	52125
1K2	Motor adapter with plug and foot	52932
2K1	Impeller	
3K1	Guidevane	
4K1	Backplate	52126
4K2	Strainer (with retaining wire)	
4K3	Rubber grommet	
4K4	Air valve core (fits inside AA7)	
4K5	Diffuser	
4K63	Foot	
4K234	Check valve	
4K290	Valve assembly (fits inside AA1)	
5K1	Gasket – backplate	
5K2	Gasket – casing	
5K3	Seal ring – guidevane	
5K7	Deflector	
5K175	O-ring connect A.V.C. tubing to AA7	

Part No.	Part Name	Pattern No.
6K1	Plug 1/8 NPT (old style)	
6K2	Plug 1/4 NPT	
6K7	Compression nut – A.V.C. tube (use with 5K175)	
6K24	Switch connector with nut	
6K65	Tubing – A.V.C. (3/16" O.D. x 9 3/4" long)	
6K68	Plug 1/2 NPT	

Part No.	Part Name	Pattern No.
10K2	Shaft seal assembly	
13K1	Bolt – adapter to casing	
13K2	Bolt – guidevane	
13K71	Bolt – motor to adapter	
13102	Bolt – foot to adapter	
13K108	Bolt – backplate to casing	
AA1	Air volume control (includes 4K290)	
AA7	Air valve (includes 4K4)	
AN015	Nozzle	
AS3	Pressure switch	

**NOTE:** 4K2 strainer not required on units with nozzle cleanout plug.

① 6K1 casing drain plug changed to 6K2 on 1981 and later models.

② Valve assembly 4K290 used to repair USG (black) only. 4K7 valve assembly no longer available.

### NOTES

---

**Xylem Inc.**

2881 East Bayard Street Ext., Suite A, Seneca Falls, NY 13148

Phone: (800) 453-6777 Fax: (888) 322-5877

[www.xylem.com/brands/gouldswatertechnology](http://www.xylem.com/brands/gouldswatertechnology)

Goulds is a registered trademark of Goulds Pumps, Inc. and is used under license. Irri-gator is a trademark of Xylem Inc. or one of its subsidiaries. Noryl and Lexan are registered trademarks of GE Plastic. Amodel is a registered trademark of Solvay. Delrin is a registered trademark of DuPont. Durez is a registered trademark of Durez Corporation, a division of Sumitomo Bakelite Company, Ltd.

© 2011 Xylem Inc. RJETPARTS December 2011

